

ITEM NO.	PART NUMBER	DESCRIPTION	QTY.
1	TR-403	5" straight Frame	1
2	SP-115	Alum Roller w/Bearings	1
3	HW-182	5/8" nyloc nut	1
4	SP-181	3/8 Pin w/ retainer	2
5	HW-161	1/2"13t 1.75" Bolt	1
6	HW-176	5/8" SAE Washer	2
7	HW-175	5/8" 11t x 6.5" Bolt	1

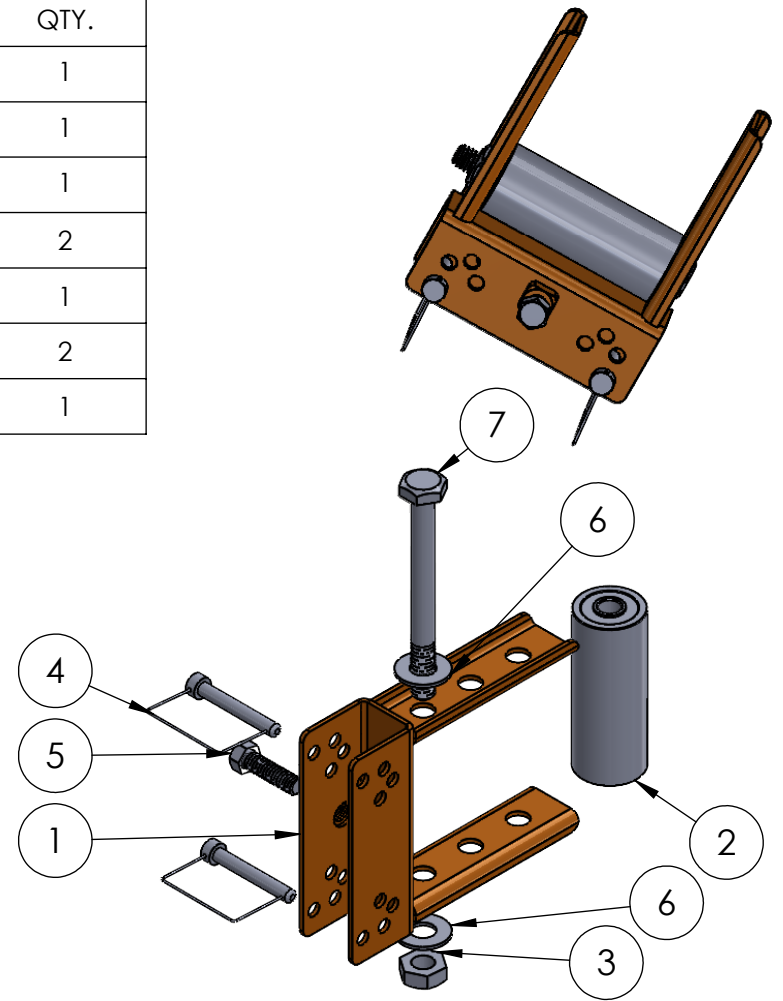
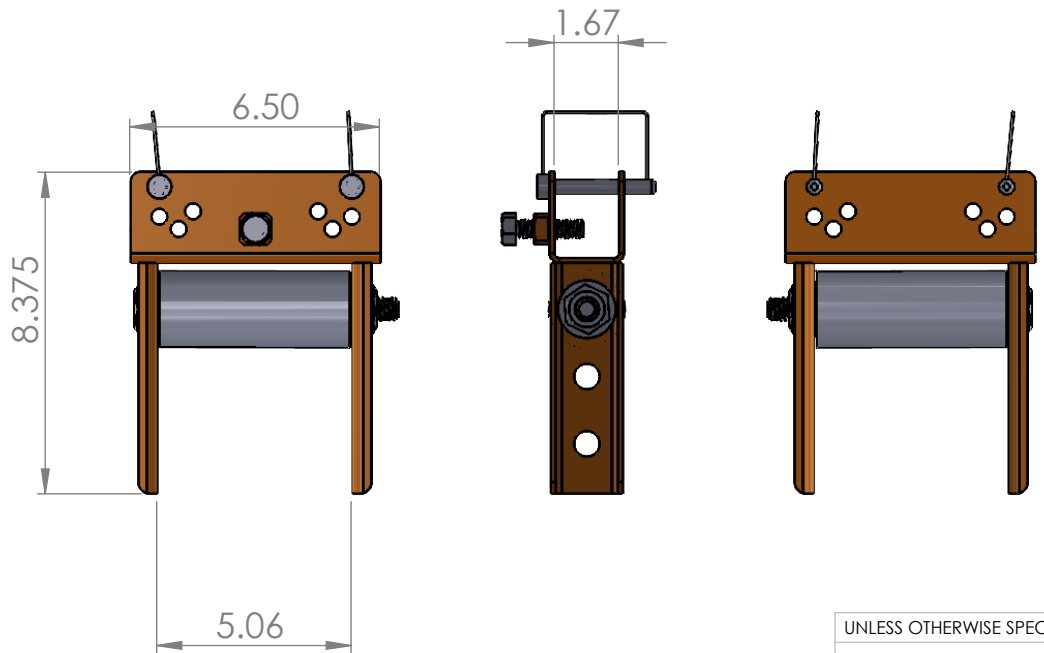

UNLESS OTHERWISE SPECIFIED:		NAME	DATE	<b>iTOOL</b> co. (865)670-3713
DIMENSIONS ARE IN INCHES TOLERANCES:		DRAWN	D. Jordan 9/29/16	
ANGULAR: MACH +1/4*BEND ±.03 TWO PLACE DECIMAL ±.01 THREE PLACE DECIMAL ±.005		CHECKED	E. James 7/24/23	TITLE: Straight 5" tray roller
INTERPRET GEOMETRIC TOLERANCING PER:		ENG APPR.		SIZE DWG. NO. <b>A TRST05</b>
MATERIAL      ????????		Q.A.		
FINISH            ???????		PROPRIETARY AND CONFIDENTIAL		SCALE: 1:5 WEIGHT: SHEET 1 OF 1
DO NOT SCALE DRAWING		THE INFORMATION CONTAINED IN THIS DRAWING IS THE SOLE PROPERTY OF iTOOL co. ANY REPRODUCTION IN PART OR AS A WHOLE WITHOUT THE WRITTEN PERMISSION OF iTOOL co. IS PROHIBITED.		