

5.14

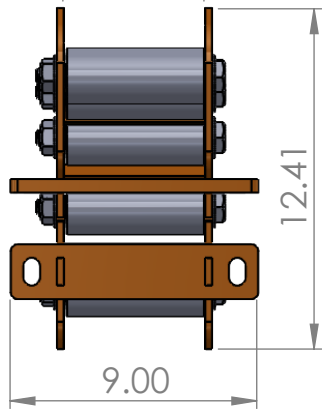

9.00

12.41

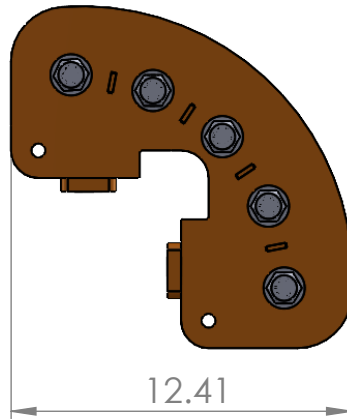

12.41

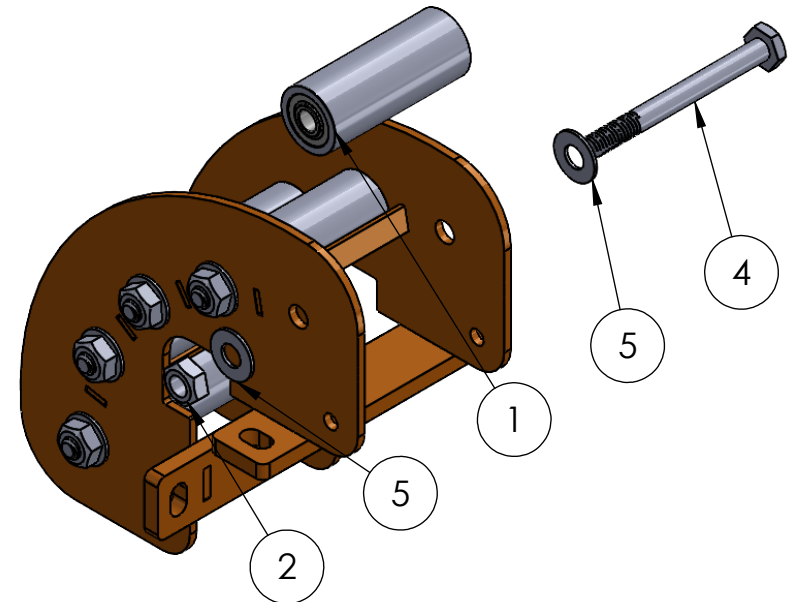

ITEM NO.	PART NUMBER	DESCRIPTION	QTY.	UNLESS OTHERWISE SPECIFIED:			iTOOLco. (865)670-3713
				DRAWN	NAME	DATE	
1	C10K-607	2" Steel Roller (with sleeve bearings)	5	E. James		2/7/24	TITLE: <b>Curb Roller 10K</b>
2	HW-182	5/8" nyloc nut	5				
3	CR10-400	Welded Frame	1				
4	HW-175	5/8" 11t x 6.5" Bolt	5				SIZE DWG. NO. REV
5	HW-176	5/8" SAE Washer	10				<b>A CR10</b>
				DIMENSIONS ARE IN INCHES TOLERANCES: ANGULAR: MACH +1/4"BEND ±.03 TWO PLACE DECIMAL ±.01 THREE PLACE DECIMAL ±.005			PROPRIETARY AND CONFIDENTIAL  THE INFORMATION CONTAINED IN THIS DRAWING IS THE SOLE PROPERTY OF iTOOL co. ANY REPRODUCTION IN PART OR AS A WHOLE WITHOUT THE WRITTEN PERMISSION OF iTOOL co. IS PROHIBITED.
				INTERPRET GEOMETRIC TOLERANCING PER:			
				FINISH Powder Coat			
				DO NOT SCALE DRAWING			SCALE: 1:5 WEIGHT: SHEET 1 OF 1

5

4

3

2

1