

# MATERIAL MANAGEMENT SYSTEM

ONE CART WITH UNLIMITED SOLUTIONS

# iTOOLco.

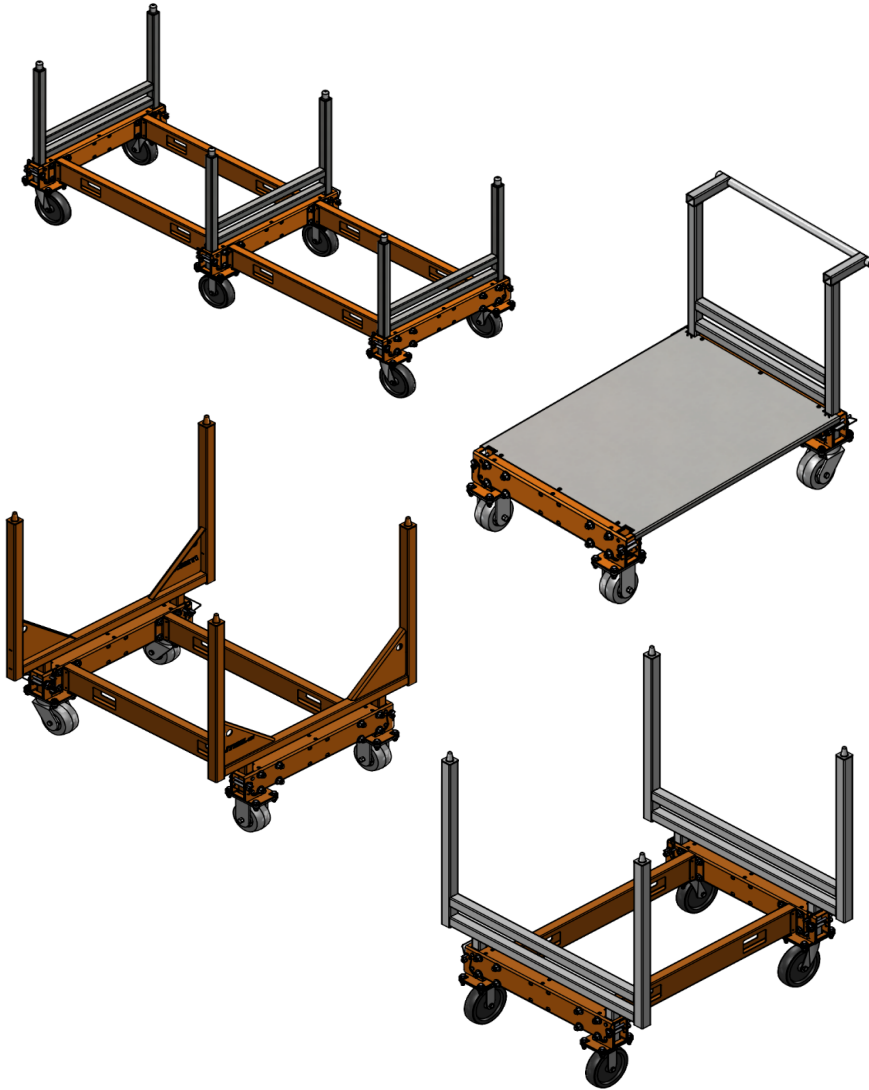

Interchangeable Uprights



Multiple Uprights Designed for Unique Jobsite Applications



Extendable Cart Design

One cart with unlimited solutions, iTOOLco's new Material Management System will handle a wide range of material. The innovative base design allows contractors to simply swap out upright brackets to accommodate anything from bundles of unistrut, to master bundles of 4" pipe, to a customized pipe tree setup. This stackable space saving design results in fewer individual carts being needed throughout the construction process. Another unique feature of the Material Management System is the ability to couple the carts together to accommodate longer materials such as 20' lengths of pipe, prefabricated racking or even bundles of cable tray. When coupled together, the cart offers a "360 degree easy pivot" whereby the coupled carts pivot on the center wheels making turning longer material a snap. In addition, the cart's wheels can fold up prior to transport so the load sits directly on the deck of a transportation vehicle for a much more stable and safe ride. Finally, unloading and loading the carts is a breeze with the built in fork pockets.

**FASTER SAFER WORKSPACE**

iTOOLco.com / 865-670-3713

# MATERIAL MANAGEMENT SYSTEM

## HOW TO PICK OUT THE CART YOU WANT

### STEP 1: Pick out your base Length:



Standard: 38" L x 34" W  
PART # MMS01



Long: 43.2" L X 34" W  
PART # MMS02

STANDARD OR LONG  
UNEXTENDED BASE EXAMPLE:

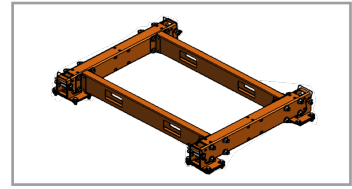

### If you want an extended cart, you will need to order an extension kit as well:

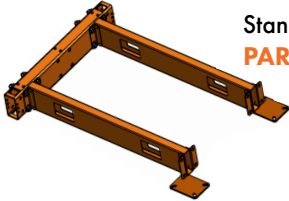

Standard: 38" L x 34" W  
PART # MMSA01

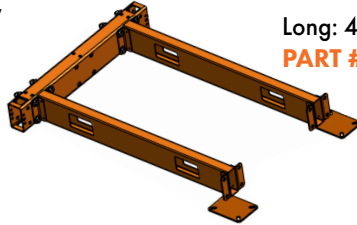

Long: 43.2" L x 34" W  
PART # MMSA01

STANDARD OR LONG  
EXTENDED BASE EXAMPLE:

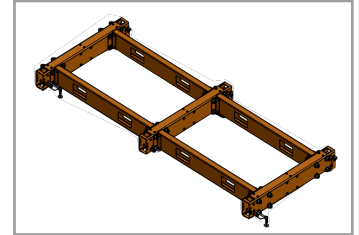

### STEP 2: Pick out your caster type:

#### STANDARD DUTY (1,000 LB RATED EACH)

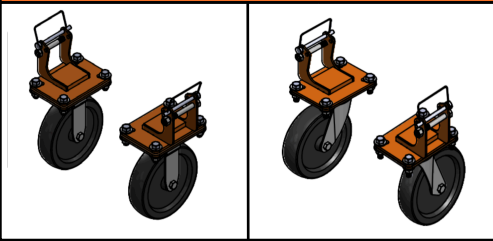

FIXED CASTER SET  
PART # MMSFDS

SWIVEL CASTER SET  
PART # MMSSDS

OR

#### HEAVY DUTY (2,500 LB RATED EACH)

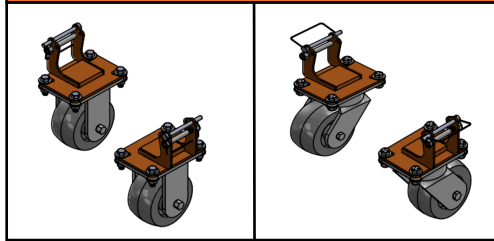

FIXED CASTER SET  
PART # MMSHDF

SWIVEL CASTER SET  
PART # MMSHDS

**Note:** Each caster set is sold as a set of two, to make a complete cart you will need two sets of casters. If you have an expanded cart, you will need one additional set of swiveling casters per extension kit.

### STEP 2: Pick out your uprights:

#### BULK STRUT

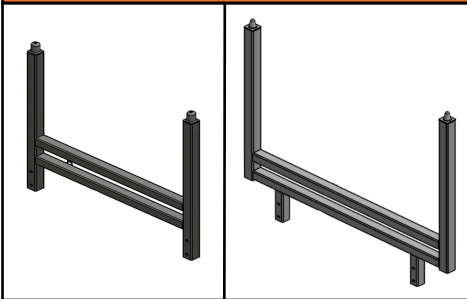

STANDARD WIDTH 32-1/4"

WIDE WIDTH 46"

PART # MMS-BSS

PART # MMS-BSW

#### BULK PIPE

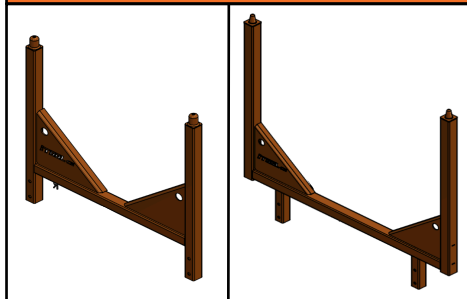

STANDARD WIDTH 32-1/4"

WIDE WIDTH 46"

PART # MMS-BPS

PART # MMS-BPW

#### FLAT CART

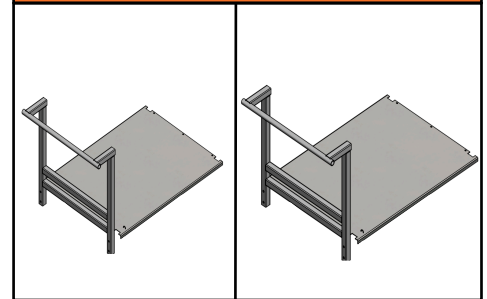

STANDARD LENGTH 32-1/4"

LONG LENGTH 46"

PART # MMS-PCS

PART # MMS-PCL



#### PIPE TREE

ONE LENGTH AVAILABLE  
PART # MMS-PT

The Pipe Tree upright is only compatible with the MMS02 base type.

MADE IN THE  
USA  
WITH GLOBAL  
COMPONENTS

6  
YEAR  
LIMITED  
WARRANTY

# MATERIAL MANAGEMENT SYSTEM

## CARTS WITH A 44" STANDARD BASE



**PURCHASE THESE ITEMS  
TO MAKE THIS CART:**

PART NUMBER	DESCRIPTION	QTY.
MMS01	44" Cart Base	1
MMS-BSS	Standard Width Strut Arms	2
<b>PICK YOUR CASTER TYPE</b>		
MMSSD	Standard Duty 4 Caster Pack	1
MMSHD	Heavy Duty 4 Caster Pack	1

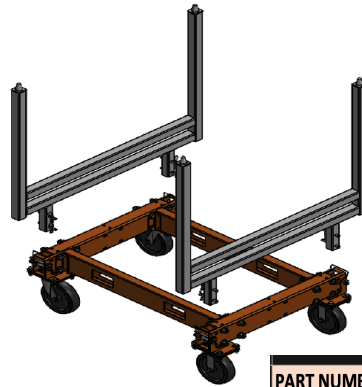

**PURCHASE THESE ITEMS  
TO MAKE THIS CART:**

PART NUMBER	DESCRIPTION	QTY.
MMS01	44" Cart Base	1
MMS-BSW	Wide Width Strut Arms	2
<b>PICK YOUR CASTER TYPE</b>		
MMSSD	Standard Duty 4 Caster Pack	1
MMSHD	Heavy Duty 4 Caster Pack	1



**PURCHASE THESE ITEMS  
TO MAKE THIS CART:**

PART NUMBER	DESCRIPTION	QTY.
MMS01	44" Cart Base	1
MMS-BPS	Standard Width Pipe Arms	2
<b>PICK YOUR CASTER TYPE</b>		
MMSSD	Standard Duty 4 Caster Pack	1
MMSHD	Heavy Duty 4 Caster Pack	1



**PURCHASE THESE ITEMS  
TO MAKE THIS CART:**

PART NUMBER	DESCRIPTION	QTY.
MMS01	44" Cart Base	1
MMS-BPW	Wide Width Pipe Arms	2
<b>PICK YOUR CASTER TYPE</b>		
MMSSD	Standard Duty 4 Caster Pack	1
MMSHD	Heavy Duty 4 Caster Pack	1



**PURCHASE THESE ITEMS  
TO MAKE THIS CART:**

PART NUMBER	DESCRIPTION	QTY.
MMS01	44" Cart Base	1
MMS-PCS	Flat Cart	2
<b>PICK YOUR CASTER TYPE</b>		
MMSSD	Standard Duty 4 Caster Pack	1
MMSHD	Heavy Duty 4 Caster Pack	1



# MATERIAL MANAGEMENT SYSTEM

## CARTS WITH A 49" LONG BASE

MADE IN THE  
**USA**  
WITH GLOBAL  
COMPONENTS

**6**  
YEAR  
LIMITED  
WARRANTY



**PURCHASE THESE ITEMS  
TO MAKE THIS CART:**

PART NUMBER	DESCRIPTION	QTY.
MMS02	49" Cart Base	1
MMS-BSS	Wide Width Strut Arms	2
<b>PICK YOUR CASTER TYPE</b>		
MMSSD	Standard Duty 4 Caster Pack	1
MMSHD	Heavy Duty 4 Caster Pack	1



**PURCHASE THESE ITEMS  
TO MAKE THIS CART:**

PART NUMBER	DESCRIPTION	QTY.
MMS02	49" Cart Base	1
MMS-BSW	Wide Width Strut Arms	2
<b>PICK YOUR CASTER TYPE</b>		
MMSSD	Standard Duty 4 Caster Pack	1
MMSHD	Heavy Duty 4 Caster Pack	1



**PURCHASE THESE ITEMS  
TO MAKE THIS CART:**

PART NUMBER	DESCRIPTION	QTY.
MMS02	49" Cart Base	1
MMS-BPS	Standard Width Pipe Arms	2
<b>PICK YOUR CASTER TYPE</b>		
MMSSD	Standard Duty 4 Caster Pack	1
MMSHD	Heavy Duty 4 Caster Pack	1



**PURCHASE THESE ITEMS  
TO MAKE THIS CART:**

PART NUMBER	DESCRIPTION	QTY.
MMS02	49" Cart Base	1
MMS-BPW	Wide Width Pipe Arms	2
<b>PICK YOUR CASTER TYPE</b>		
MMSSD	Standard Duty 4 Caster Pack	1
MMSHD	Heavy Duty 4 Caster Pack	1



**PURCHASE THESE ITEMS  
TO MAKE THIS CART:**

PART NUMBER	DESCRIPTION	QTY.
MMS02	49" Cart Base	1
MMS-PCL	Flat Cart	2
<b>PICK YOUR CASTER TYPE</b>		
MMSSD	Standard Duty 4 Caster Pack	1
MMSHD	Heavy Duty 4 Caster Pack	1



**PURCHASE THESE ITEMS  
TO MAKE THIS CART:**

PART NUMBER	DESCRIPTION	QTY.
MMS02	49" Cart Base	1
MMS-PT	Pipe Tree	2
<b>PICK YOUR CASTER TYPE</b>		
MMSSD	Standard Duty 4 Caster Pack	1
MMSHD	Heavy Duty 4 Caster Pack	1

# MATERIAL MANAGEMENT SYSTEM

## CARTS WITH A 85" STANDARD EXTENDED BASE

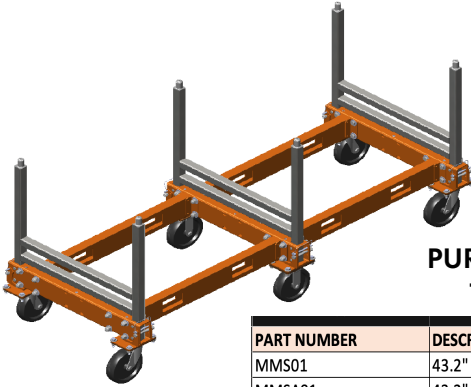

**PURCHASE THESE ITEMS TO MAKE THIS CART:**

PART NUMBER	DESCRIPTION	QTY.
MMS01	43.2" Extended Cart Base	1
MMSA01	43.2" Extension Piece	1
MMS-BSS	Standard Width Strut Arms	3
<b>PICK YOUR CASTER TYPE</b>		
MMSSD	Standard Duty 4 Caster Pack	1
MMSHD	Heavy Duty 4 Caster Pack	1
<b>YOU'LL ALSO NEED AN ADDITIONAL CASTER SET TO MATCH</b>		
MMSSDS	Swiveling Standard Duty 2 Caster Pack	1
MMSHDS	Swiveling Heavy Duty 2 Caster Pack	1

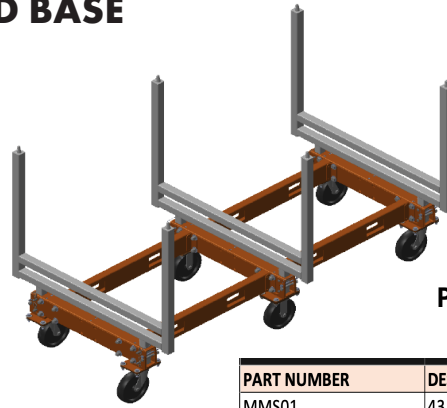

**PURCHASE THESE ITEMS TO MAKE THIS CART:**

PART NUMBER	DESCRIPTION	QTY.
MMS01	43.2" Extended Cart Base	1
MMSA01	43.2" Extension Piece	1
MMS-BSW	Wide Width Strut Arms	3
<b>PICK YOUR CASTER TYPE</b>		
MMSSD	Standard Duty 4 Caster Pack	1
MMSHD	Heavy Duty 4 Caster Pack	1
<b>YOU'LL ALSO NEED AN ADDITIONAL CASTER SET TO MATCH</b>		
MMSSDS	Swiveling Standard Duty 2 Caster Pack	1
MMSHDS	Swiveling Heavy Duty 2 Caster Pack	1

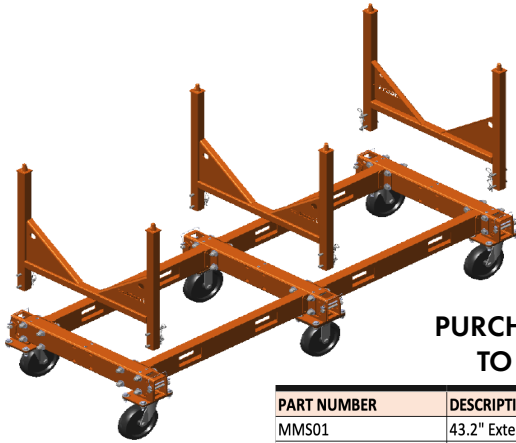

**PURCHASE THESE ITEMS TO MAKE THIS CART:**

PART NUMBER	DESCRIPTION	QTY.
MMS01	43.2" Extended Cart Base	1
MMSA01	43.2" Extension Piece	1
MMS-BPS	Standard Width Pipe Arms	3
<b>PICK YOUR CASTER TYPE</b>		
MMSSD	Standard Duty 4 Caster Pack	1
MMSHD	Heavy Duty 4 Caster Pack	1
<b>YOU'LL ALSO NEED AN ADDITIONAL CASTER SET TO MATCH</b>		
MMSSDS	Swiveling Standard Duty 2 Caster Pack	1
MMSHDS	Swiveling Heavy Duty 2 Caster Pack	1



**PURCHASE THESE ITEMS TO MAKE THIS CART:**

PART NUMBER	DESCRIPTION	QTY.
MMS01	43.2" Extended Cart Base	1
MMSA01	43.2" Extension Piece	1
MMS-BPW	Wide Width Pipe Arms	3
<b>PICK YOUR CASTER TYPE</b>		
MMSSD	Standard Duty 4 Caster Pack	1
MMSHD	Heavy Duty 4 Caster Pack	1
<b>YOU'LL ALSO NEED AN ADDITIONAL CASTER SET TO MATCH</b>		
MMSSDS	Swiveling Standard Duty 2 Caster Pack	1
MMSHDS	Swiveling Heavy Duty 2 Caster Pack	1

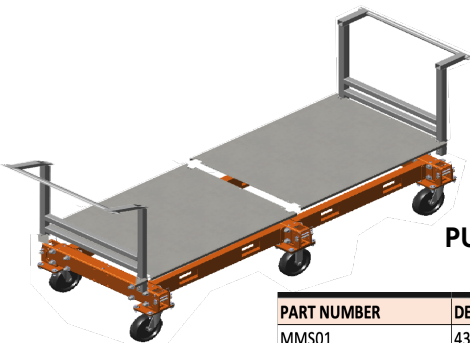

**PURCHASE THESE ITEMS TO MAKE THIS CART:**

PART NUMBER	DESCRIPTION	QTY.
MMS01	43.2" Extended Cart Base	1
MMSA01	43.2" Extension Piece	1
MMS-PCS	Flat Cart (Short)	2
<b>PICK YOUR CASTER TYPE</b>		
MMSSD	Standard Duty 4 Caster Pack	1
MMSHD	Heavy Duty 4 Caster Pack	1
<b>YOU'LL ALSO NEED AN ADDITIONAL CASTER SET TO MATCH</b>		
MMSSDS	Swiveling Standard Duty 2 Caster Pack	1
MMSHDS	Swiveling Heavy Duty 2 Caster Pack	1



# MATERIAL MANAGEMENT SYSTEM

## CARTS WITH A 95" LONG EXTENDED BASE

MADE IN THE  
**USA**  
WITH GLOBAL  
COMPONENTS

**6**  
YEAR  
LIMITED  
WARRANTY

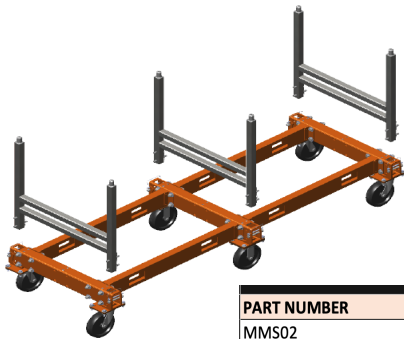

**PURCHASE THESE ITEMS  
TO MAKE THIS CART:**

PART NUMBER	DESCRIPTION	QTY.
MMSO2	43.2" Extended Cart Base	1
MMSA02	43.2" Extension Piece	1
MMS-BSS	Standard Width Strut Arms	3
<b>PICK YOUR CASTER TYPE</b>		
MMSSD	Standard Duty 4 Caster Pack	1
MMSHD	Heavy Duty 4 Caster Pack	1
<b>YOU'LL ALSO NEED AN ADDITIONAL CASTER SET TO MATCH</b>		
MMSSDS	Swiveling Standard Duty 2 Caster Pack	1
MMSHDS	Swiveling Heavy Duty 2 Caster Pack	1

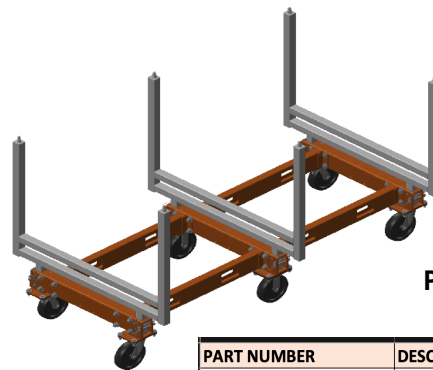

**PURCHASE THESE ITEMS  
TO MAKE THIS CART:**

PART NUMBER	DESCRIPTION	QTY.
MMSO2	43.2" Extended Cart Base	1
MMSA02	43.2" Extension Piece	1
MMS-BSW	Wide Width Strut Arms	3
<b>PICK YOUR CASTER TYPE</b>		
MMSSD	Standard Duty 4 Caster Pack	1
MMSHD	Heavy Duty 4 Caster Pack	1
<b>YOU'LL ALSO NEED AN ADDITIONAL CASTER SET TO MATCH</b>		
MMSSDS	Swiveling Standard Duty 2 Caster Pack	1
MMSHDS	Swiveling Heavy Duty 2 Caster Pack	1

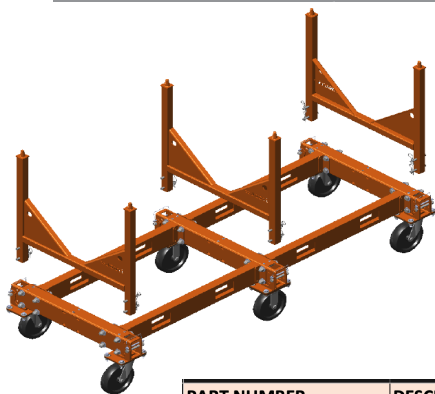

**PURCHASE THESE ITEMS  
TO MAKE THIS CART:**

PART NUMBER	DESCRIPTION	QTY.
MMSO2	43.2" Extended Cart Base	1
MMSA02	43.2" Extension Piece	1
MMS-BPS	Standard Width Pipe Arms	3
<b>PICK YOUR CASTER TYPE</b>		
MMSSD	Standard Duty 4 Caster Pack	1
MMSHD	Heavy Duty 4 Caster Pack	1
<b>YOU'LL ALSO NEED AN ADDITIONAL CASTER SET TO MATCH</b>		
MMSSDS	Swiveling Standard Duty 2 Caster Pack	1
MMSHDS	Swiveling Heavy Duty 2 Caster Pack	1



**PURCHASE THESE ITEMS  
TO MAKE THIS CART:**

PART NUMBER	DESCRIPTION	QTY.
MMSO2	43.2" Extended Cart Base	1
MMSA02	43.2" Extension Piece	1
MMS-BPW	Wide Width Pipe Arms	3
<b>PICK YOUR CASTER TYPE</b>		
MMSSD	Standard Duty 4 Caster Pack	1
MMSHD	Heavy Duty 4 Caster Pack	1
<b>YOU'LL ALSO NEED AN ADDITIONAL CASTER SET TO MATCH</b>		
MMSSDS	Swiveling Standard Duty 2 Caster Pack	1
MMSHDS	Swiveling Heavy Duty 2 Caster Pack	1



**PURCHASE THESE ITEMS  
TO MAKE THIS CART:**

PART NUMBER	DESCRIPTION	QTY.
MMSO2	43.2" Extended Cart Base	1
MMSA02	43.2" Extension Piece	1
MMS-PCL	Flat Cat (Long)	2
<b>PICK YOUR CASTER TYPE</b>		
MMSSD	Standard Duty 4 Caster Pack	1
MMSHD	Heavy Duty 4 Caster Pack	1
<b>YOU'LL ALSO NEED AN ADDITIONAL CASTER SET TO MATCH</b>		
MMSSDS	Swiveling Standard Duty 2 Caster Pack	1
MMSHDS	Swiveling Heavy Duty 2 Caster Pack	1

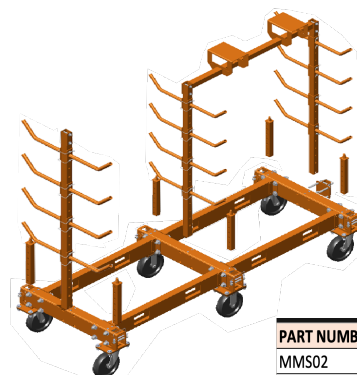

**PURCHASE THESE ITEMS  
TO MAKE THIS CART:**

PART NUMBER	DESCRIPTION	QTY.
MMSO2	43.2" Extended Cart Base	1
MMSA02	43.2" Extension Piece	1
MMS-PT	Pipe Tree Upright	3
<b>PICK YOUR CASTER TYPE</b>		
MMSSD	Standard Duty 4 Caster Pack	1
MMSHD	Heavy Duty 4 Caster Pack	1
<b>YOU'LL ALSO NEED AN ADDITIONAL CASTER SET TO MATCH</b>		
MMSSDS	Swiveling Standard Duty 2 Caster Pack	1
MMSHDS	Swiveling Heavy Duty 2 Caster Pack	1