

IToolCo.

(865)670-3713

TITLE:

NAME	D. Jordan	DATE	??
SIZE	DWG. NO.	REV	
A	PFC3000		
SCALE: 1:20	WEIGHT:	SHEET 1 OF 2	

5

4

3

2

1

ITEM NO.	PART NUMBER	DESCRIPTION	QTY.
1	PFC-401	Cart Base	1
2	PFC-404M	50" of BM-63 Machined	2
3	PFC-405	Extendable Foot	4
4	PFC-406	Top Bar	1
5	PFC-407	Rack Bar	6
6	PFC-403	Forklift Pocket	2
7	SP-001.2	Pull Pop Pin	2
8	SP-146	Fixed Wheel	2
9	SP-147	Caster wheel w/ break	2
10	HW-142	.375x 16 x 3. bolt	4
11	HW-166	1/2" Flat Washer	40
12	HW-306	1/2" 13T x nyloc nut	4
13	SP-181	3/8 Pin w/ retainer	20
14	HW-150	3/8" nyloc nut	16
15	HW-150	3/8" Nylock Nut	16
16	HW-254	1/2" X 3"L Clevis pin	2
17	HW-321	12mm flat washer	4
18	HW-222	1/8" cotter pin	2

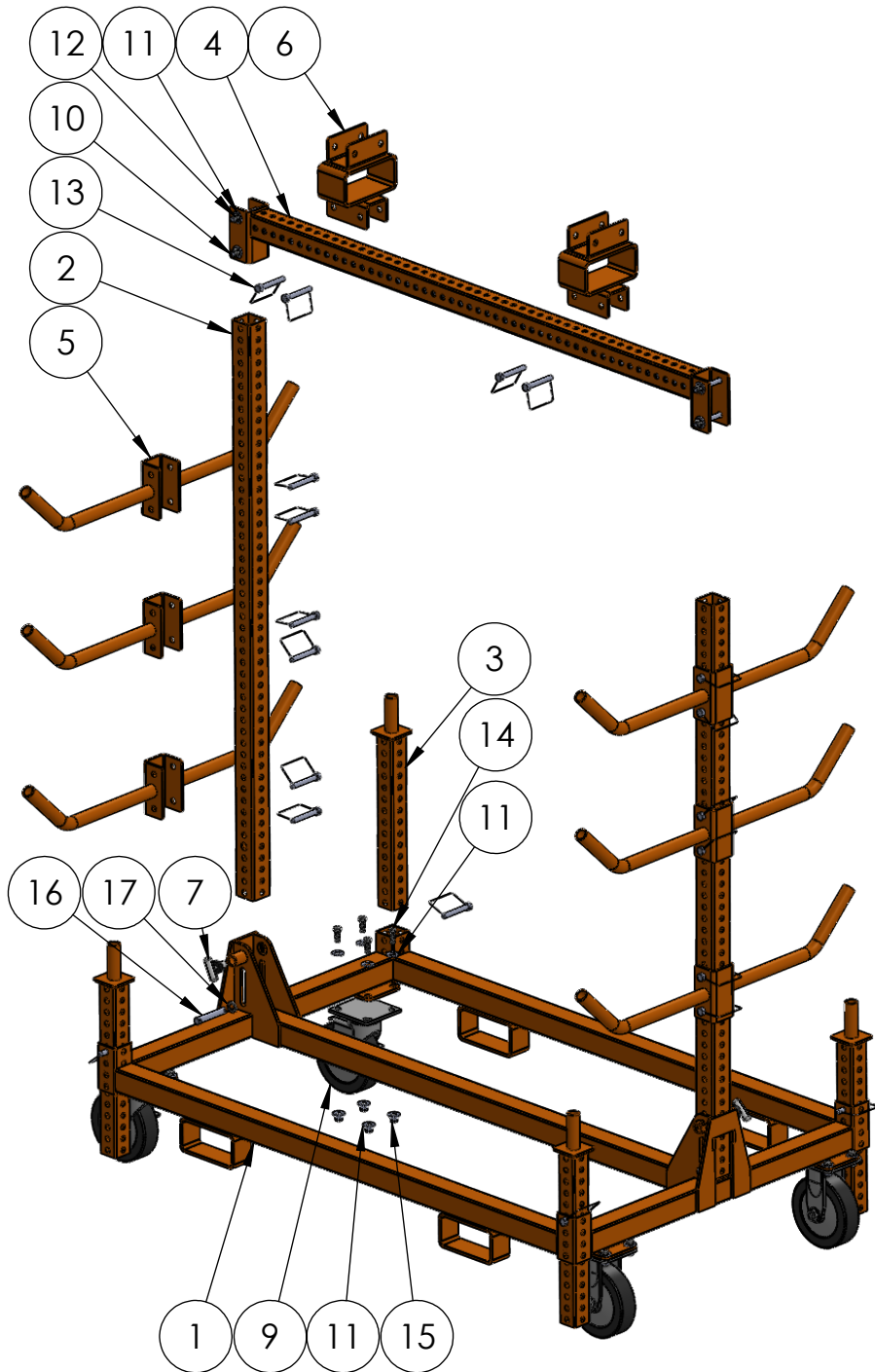

iTOOL.co (865)670-3713

TITLE:

PROPRIETARY AND CONFIDENTIAL

THE INFORMATION CONTAINED IN THIS DRAWING IS THE SOLE PROPERTY OF iTOOL co. ANY REPRODUCTION IN PART OR AS A WHOLE WITHOUT THE WRITTEN PERMISSION OF iTOOL co. IS PROHIBITED.

SIZE A	DWG. NO. PFC3000	REV
------------------	----------------------------	-----

Date	WEIGHT:	SHEET 2 OF 2
------	---------	--------------